

Subaru Forester

Body:

Year : 2005 -;

V: 2.0

VIN:-

Steel
Aluminum

TYPE :22.787
TYPE :22.786

Gytis Autek^{AS}

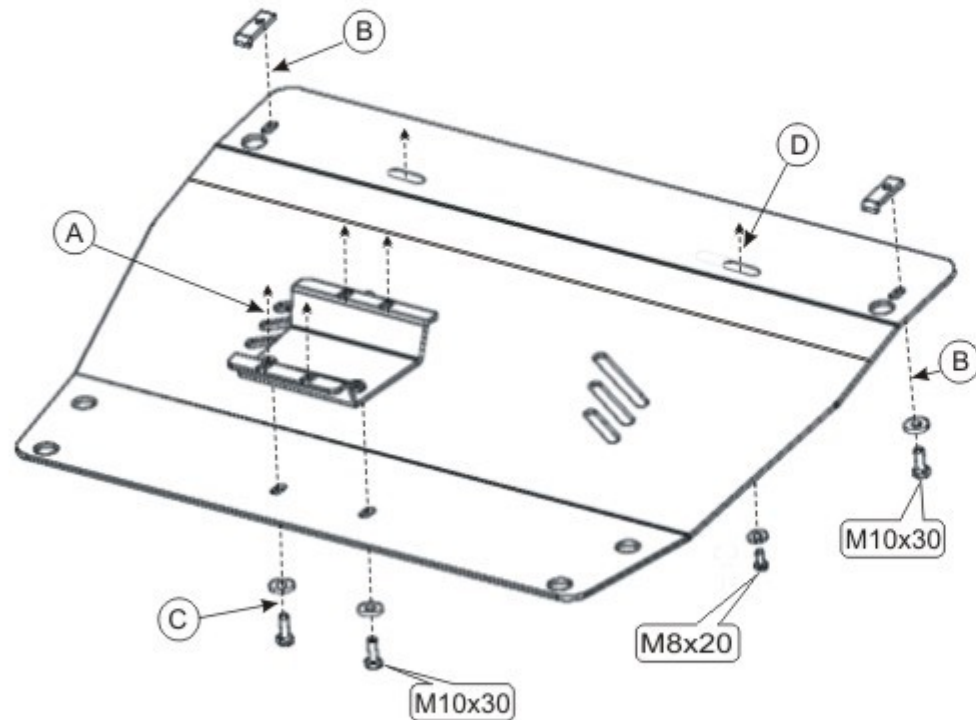

1. Remove regular plastic dust guard
2. Remove regular bearing element from the front-axle beam
3. Fix bearing element of the skid plate to regular apertures (A)
4. Fix the skid plate to installed element with bolts M10x30 (C)
5. Fix the front part of the skid plate with bolts M 10x30 and embedded slats (B)
6. Fix bolts M8x20 into regular apertures (D)
7. Tighten all screw joints

